

ARHT シリーズめねじ

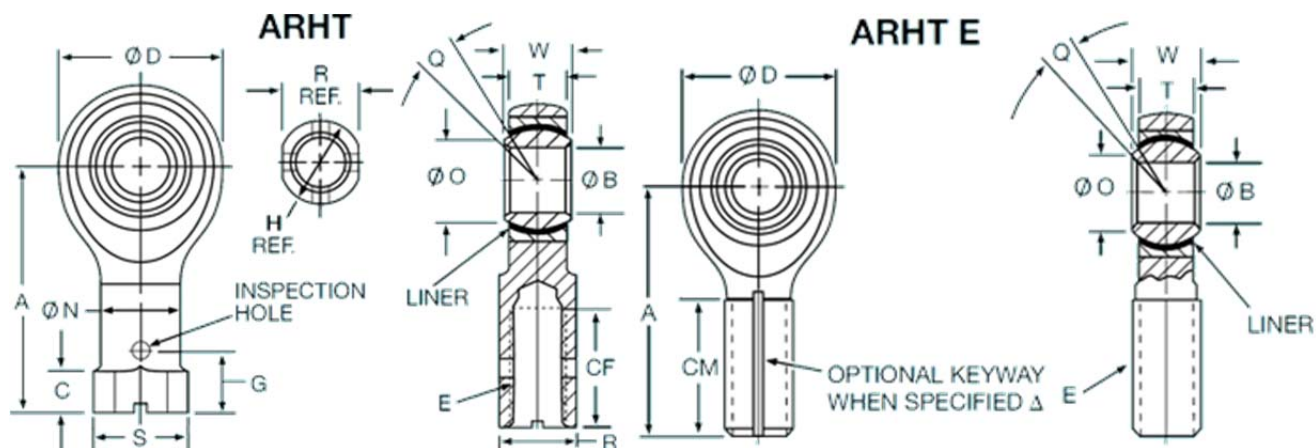

型 式	A (Inch)	B (Inch)	CM (Inch)	φD (Inch)	E (Inch)	T (Inch)	Q (°)	W (Inch)	Weight (lbs.)
ARHT4(R)	1.469	1/4	0.750	0.806	5/16 UNF	0.337	5	0.375	0.084
ARHTL4(R)	1.469	1/4	0.750	0.806	5/16 UNF	0.337	5	0.375	0.084
ARHT5(R)	1.625	5/16	0.875	0.900	3/8 UNF	0.337	14	0.437	0.102
ARHTL5(R)	1.625	5/16	0.875	0.900	3/8 UNF	0.337	14	0.437	0.102
ARHT6(R)	1.812	3/8	1.000	1.025	7/16 UNF	0.416	9	0.500	0.160
ARHTL6(R)	1.812	3/8	1.000	1.025	7/16 UNF	0.416	9	0.500	0.160
ARHT7(R)	2.000	7/16	1.125	1.150	1/2 UFNF	0.452	10	0.562	0.230
ARHTL7(R)	2.000	7/16	1.125	1.150	1/2 UFNF	0.452	10	0.562	0.230
ARHT8(R)	2.250	1/2	1.250	1.337	5/8 UNF	0.515	9	0.625	0.340
ARTL6(R)	1.812	3/8	1.000	1.025	3/8 UNF	0.416	8	0.500	0.161
ARTL8(R)	2.250	1/2	1.250	1.337	1/2 UNF	0.515	9	0.625	0.325