

ARHT シリーズおねじ

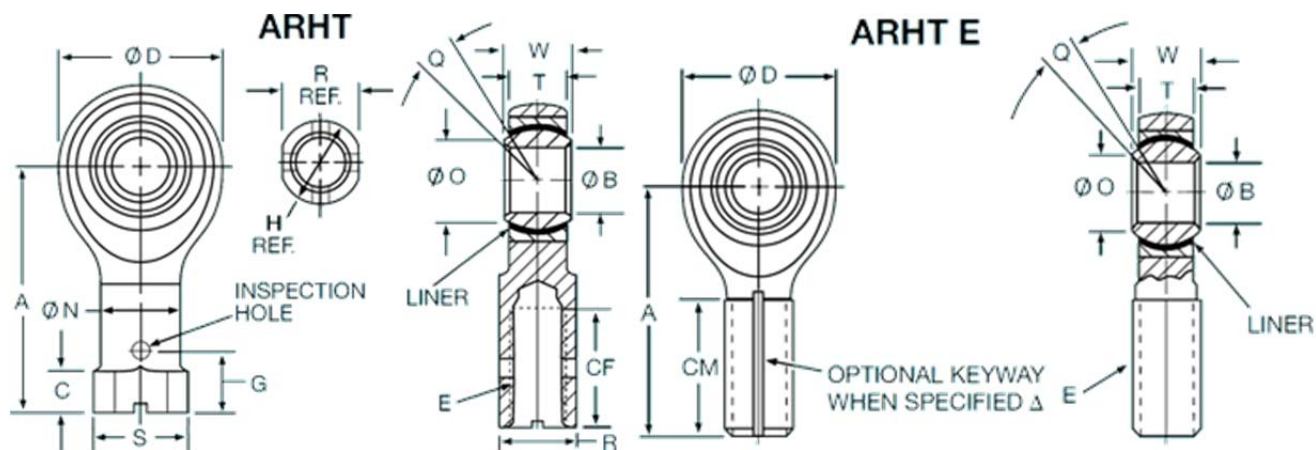

型式	A (Inch)	B (Inch)	CM (Inch)	φD (Inch)	E	T (Inch)	Q (°)	W (Inch)	Weight (lbs.)
ARHT4E(R)	1.562	1/4	0.968	0.806	5/16-UNF	0.337	5	0.375	0.067
ARHTL4E(R)	1.562	1/4	0.968	0.806	5/16-UNF	0.337	5	0.375	0.067
ARHT5E(R)	1.875	5/16	1.1875	0.900	3/8-UNF	0.337	14	1.437	0.095
ARHTL5E(R)	1.875	5/16	1.1875	0.900	3/8-UNF	0.337	14	1.437	0.095
ARHT6E(R)	1.938	3/8	1.187	1.025	7/16-UNF	0.416	9	0.500	0.140
ARHTL6E(R)	1.938	3/8	1.187	1.025	7/16-UNF	0.416	9	0.500	0.140
ARHT6E2001	1.938	3/8	1.187	1.025	1/2 UNF	0.416	9	0.500	0.151
ARHTL6E2001	1.938	3/8	1.187	1.025	1/2 UNF	0.416	9	0.500	0.151
ARHT7E(R)	2.125	7/16	1.281	1.150	1/2-UNF	0.425	10	0.562	0.210
ARHTL7E(R)	2.125	7/16	1.281	1.150	1/2-UNF	0.425	10	0.562	0.210
ARHT8E(R)	2.438	1/2	1.468	1.337	5/8-UNF	0.515	9	0.625	0.330
ARHTL8E(R)	2.438	1/2	1.468	1.337	5/8-UNF	0.515	9	0.625	0.330
ARHT10E(R)	2.625	5/8	1.562	1.525	3/4-UNF	0.577	12	0.750	0.480
ARHTL10E(R)	2.625	5/8	1.562	1.525	3/4-UNF	0.577	12	0.750	0.480
ARHT12E(R)	2.875	3/4	1.687	1.775	7/8-UNF	0.640	13	0.875	0.730