

Pressure Transducer Model  
圧力変換器 型式 PRB-1MP~10MP

仕様 (Specifications)

● 負荷特性 (Loading performance)

定格容量 Rated capacity	: 1 MPa, 2 MPa, 3 MPa, 5 MPa, 10 MPa $\triangle A$
許容過負荷 Safe overload	: 150 %R.C.
限界過負荷 Ultimate overload	: 300 %R.C.
定格出力 Rated output	: 1.5 mV/V $\pm$ 0.015 mV/V (PRB-1MP:1 mV/V $\pm$ 0.01 mV/V)
非直線性 Non-linearity	: 0.2 %R.O. (PRB-1MP:0.3 %R.O.)
ヒステリシス Hysteresis	: 0.2 %R.O. (PRB-1MP:0.3 %R.O.)
繰り返し性 Repeatability	: 0.3 %R.O.

● 電気特性 (Electrical performance)

推奨印加電圧 Recommended excitation	: 6 V以下
最大印加電圧 Maximum excitation	: 10 V
零バランス Zero balance	: $\pm$ 0.045 mV/V (PRB-1MP: $\pm$ 0.05 mV/V)
入力抵抗 Input resistance	: 350 $\Omega$ $\pm$ 3.5 $\Omega$
出力抵抗 Output resistance	: 350 $\Omega$ $\pm$ 3.5 $\Omega$
絶縁抵抗 (ブリッジ-本体) Insulation resistance	: 1000 M $\Omega$ 以上 (DC 50V)

● 温度特性 (Temperature performance)

温度補償範囲 Compensated temperature range	: -10 $^{\circ}$ C to 60 $^{\circ}$ C
許容温度範囲 Safe temperature range	: -15 $^{\circ}$ C to 100 $^{\circ}$ C
零点の温度影響 Temperature effect on zero balance	: 0.2 %R.O./10 $^{\circ}$ C
出力の温度影響 Temperature effect on output	: 0.2 %LOAD/10 $^{\circ}$ C

● その他 (The others)

コネクタ Connector	: NDI-7P-R (レセプタクル) 付 Receptacle
コネクタ型式 Connector model	: PRC03-21A10-7F
ケーブル Cable	: CAC-101-5M (別売品) Option
保護等級 IP Class	: IP64 相当 (コネクタ部除く) Equivalent to IP64 (except connector)
起歪体の材質 Element material	: ステンレス鋼 Stainless steel
疲労寿命 Fatigue life	: 定格負荷で10 <sup>6</sup> 回 10 <sup>6</sup> times on rated load

配線図  
Wiring

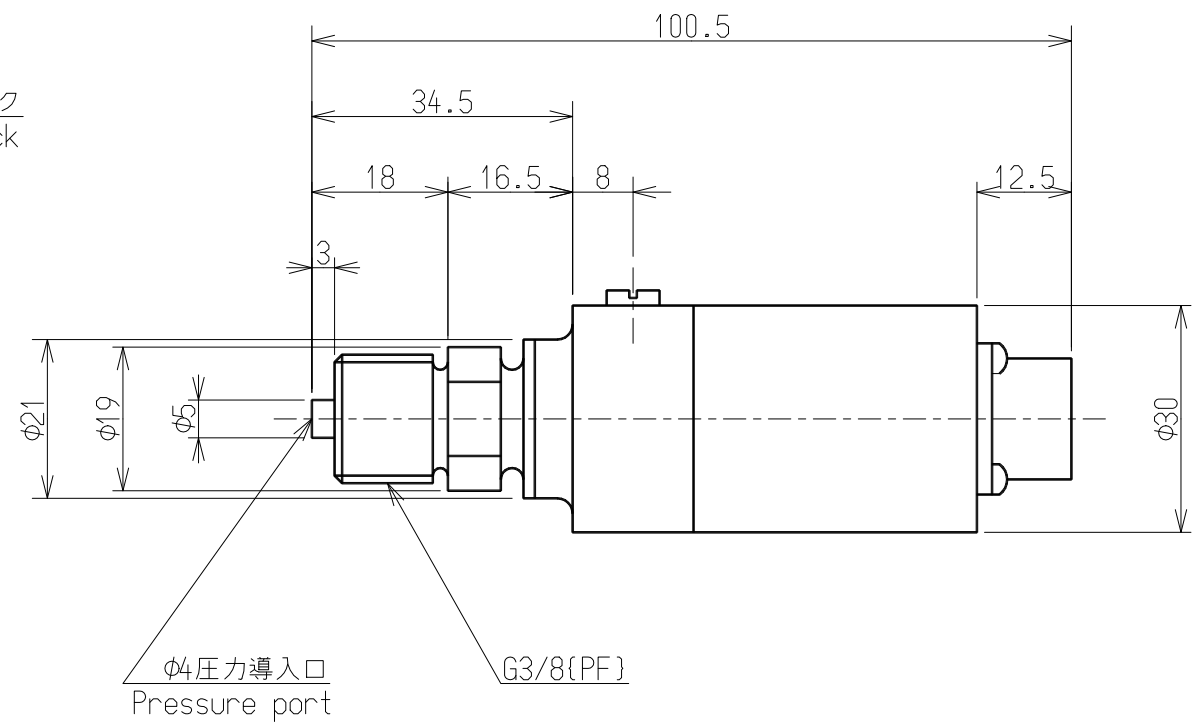
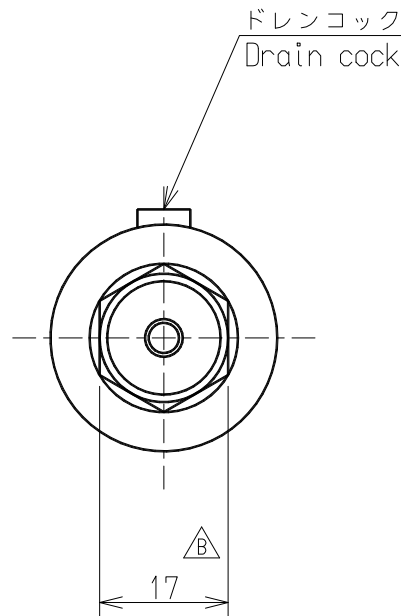
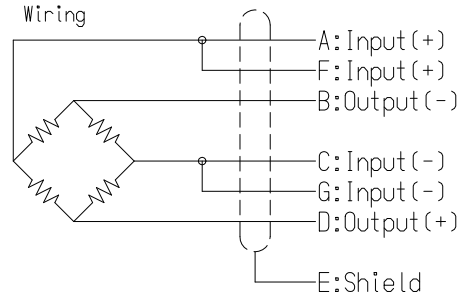

公布
K
S
T
F

符号 MARK	日付 DATE	変更事項 REASON	ECN NO.	担当 ENGINEER	承認 APPROVED
B	2016/03/23	KN16-0146		K.KON	H.AOI
A	2003/06/06	KN03-0318		N.MIUCHI	Y.SHINOHARA
-	1999/07/26	NEW		K.EGUCHI	A.MUROHASHI

ミネベア株式会社  
MINEBEA CO.,LTD.  
計測機器事業部

承認 APPROVED	チェック CHECKED	描画 DRAWN
H.Aoi	A.Ishioaka	K.KON

単位 UNIT	mm
尺度 SCALE	Free
寸法 L	公差
<L $\leq$ 4	$\pm$ 0.1
4<L $\leq$ 16	$\pm$ 0.2
16<L $\leq$ 63	$\pm$ 0.3
63<L $\leq$ 250	$\pm$ 0.5
250<L $\leq$ 1000	$\pm$ 0.8
角度 DEG	$\pm$ 0.5

材質 MATERIAL	作成日 DATE	2016.03.23
表面粗さ SURF.ROUGH.	品名 DESCRIPTION	外觀仕様図/OUTLINE
熱処理 HEAT TREAT.	品番 PART NO. (MODEL NO.)	PRB-1MP to 10MP
表面処理 FINISH	図番 DRAWING NO.	KT50839-2
	葉番 SHEET	
	改訂 REV.	B